

Planning documents SYNCHRO



GUNTAMATIC HEIZTECHNIK

Table of contents

	Page
1 Introduction	2
1.1 Brief description.....	3
1.2 Boiler structure	5
1.3 Further information	5
2 Important indications.....	6
2.1 Initial operation	6
2.2 Operation	6
3 Planning.....	6
3.1 Planning documents.....	6
3.2 Variety type	7
3.3 Guidelines	7
3.4 Boiler room	8
3.5 Flue and flue connection	9
3.6 Hydraulic connections	11
3.7 Electrical connection	11
3.8 Heat distribution	11
4..... Fuel.....	12
Attachments	13

1 Introduction

Thank you for your interest in the wood carburettor boiler **SYNCHRO**. These planning documents should support the customer, installation and heating engineer in providing all relevant information for the planning and configuration of the heating system.

This manual will provide you with information for the integration of the wood carburettor boiler into a new or existing heating system. Use this brochure as a reference guide or guideline document during planning.

1.1 Brief description

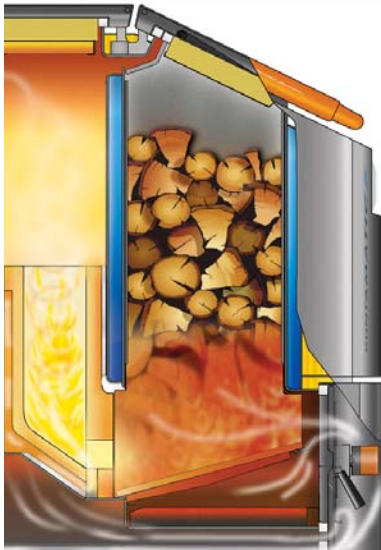

- Easy-to-get-at chamber, upper filling doors
- Extremely large filling chamber: 170 L
- Thick-walled filling shaft lining
- Integrated low temperature carbonization gas intake duct
- More slanted, durable and firmer cast grate
- Simple ash removal, large ash compartment to empty at any time

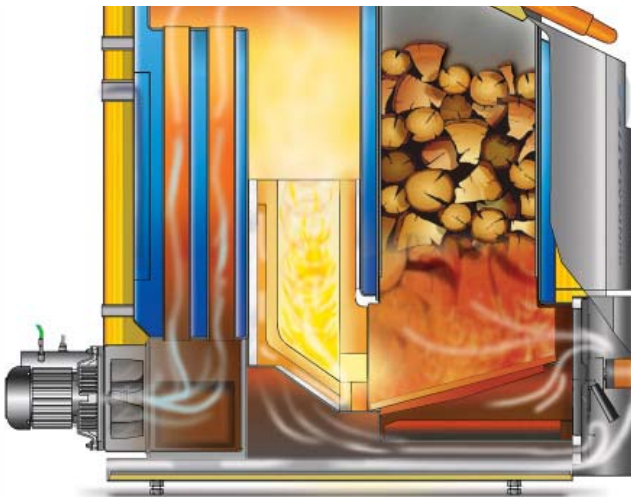

- High primary and secondary pre-heating air
- Simple coordination of the combustion air and ash gate settings, depending on the wood quality
- Well insulated fireclay combustion chamber withstanding very high temperatures
- High combustion temperatures, good mix and longer burn-out route guarantee a high degree of efficiency with reduced emissions
- Flue tube connection below, suitable for any connection situation
- Tubular heat exchange with integrated return from heating

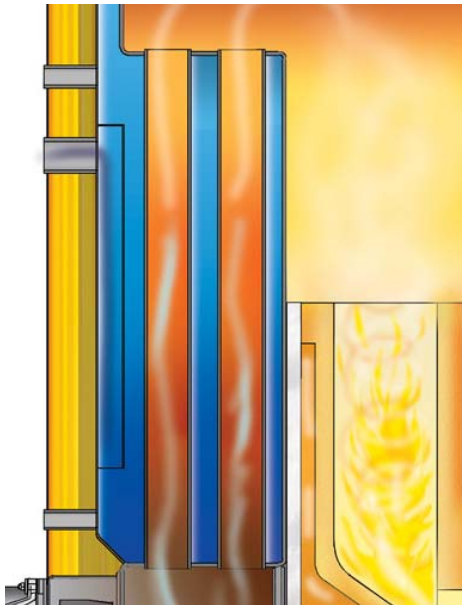

- Extensive tubular heat exchanger (12 tubes enhanced quality)
- Protected combustion chamber for a long operational life
- Large and hot burn-out zone
- With lateral burner fuel flange (best equipment for a combined operation with oil burner)



- Easy to use menu-guided control with speed-dial button
- Microprocessor system regulates the induced draft fan and the primary and secondary air engine continuously
- Better ease of use thanks to the ingenious glut conservation function
- Double regulation difference (boiler/buffer; buffer/boiler)
- Speed control of the boiler and storage Ladepumpe (supercharger)
- Hot water preparation and heating pumps are time-controlled

1.2 Boiler structure

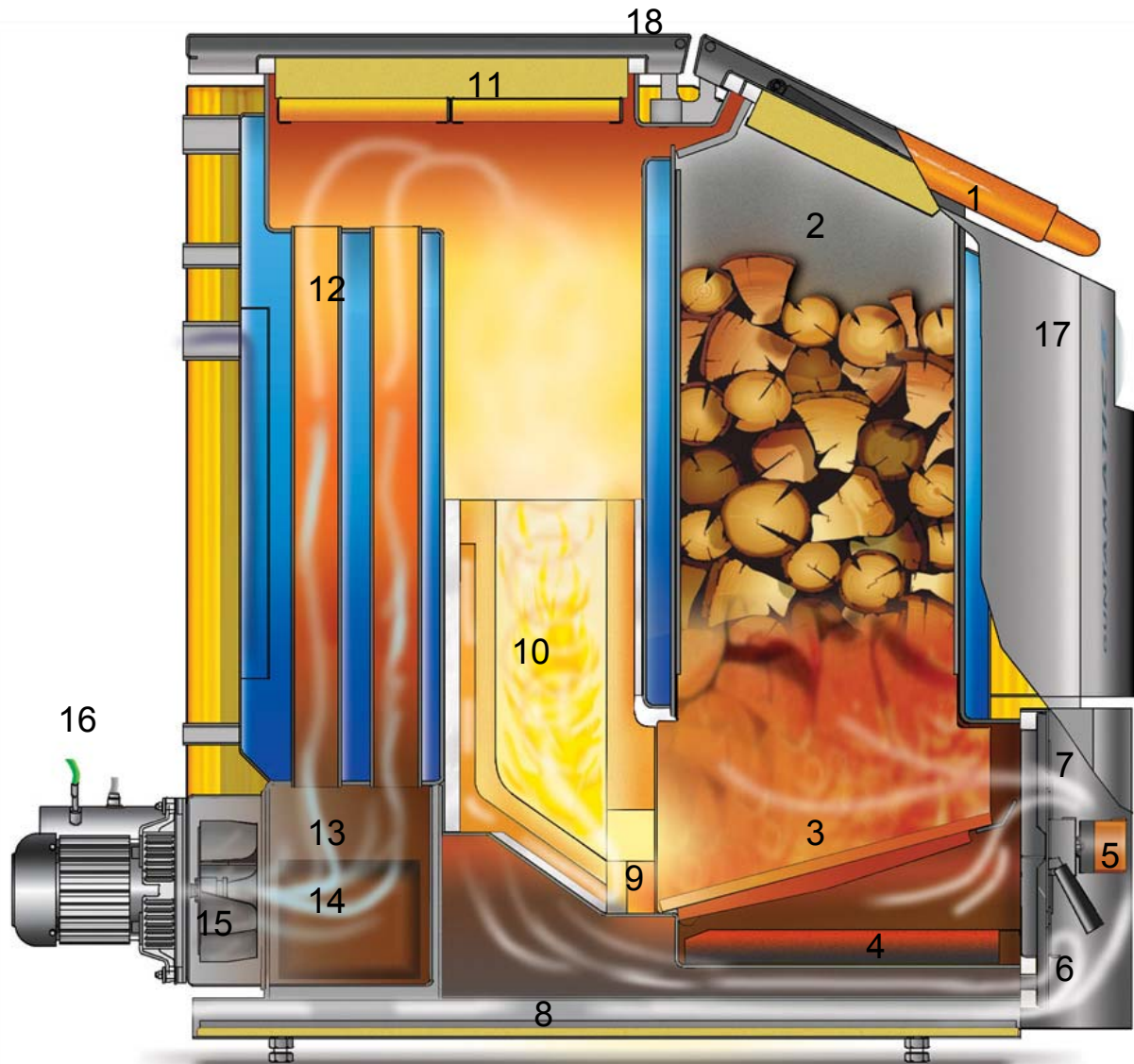

1. Top filling cover with suction canal
2. Filling chamber with protective lining
3. Hot cast grate
4. Ash storage compartment
5. Primary and secondary air motor
6. Secondary air
7. Primary air
8. Pre-heating of ground air
9. Secondary air blast pipe
10. High temperature combustion chamber
11. Cleaning cover
12. Tubular heat exchange
13. Dust removal zone
14. Cleaning opening
15. Induced draught fan
16. Flue gas sensor
17. Microprocessor control with menu-guided operation
18. Transportation hooks

1.3 Further information

The documentation of SYNCHRO consists of:

- Planning documents
- Installation and operating instructions

2 Important information

There is the most modern technology in SYNCHRO that guarantees a secured and environmentally friendly operation. If a planning error in the installation is not detected and corrected, this can lead to personal and / or material damage. To avoid accidents and damage to the heating system and the building, please note the information given here and in the "Installation and operation instructions".

2.1 Initial operation

The **SYNCHRO** must be put into initial operation by a Guntamatic engineer. He will check that the system has been assembled in accordance with the schematics and will adjust the controls to the system. The operator will also be informed about the operation and cleaning intervals.

2.2 Operation

The system operator will operate the **SYNCHRO** in accordance with the "installation and operating instructions".

3 Planning

The planning preparation for the SYNCHRO involves providing the planning documents and acquisition of existing standards and legislation.

3.1 Planning documents

Keep the following planning documents ready for the planning.

Boiler room outline

By means of the boiler room outline, the optimal site and floor space and the combustion air supply can be checked or specified.

Planning information

In this band you will find the following planning documents:

- Description of the necessary equipment components on site
- Calculation formulas to calculate the expansion volume
- Schemes for the planning of hydraulic integration
- Exhaust gas data for the fireplace system planning



Important: The boiler room, flue, heating system and electrical installation must all comply with the relevant standards and legal specifications.

3.2 Variety type

Determine the necessary performance based on the heating load calculation.

3.3 Guide values

Fundamentally, the size of the SYNCHRO wood carburettor boiler would be calculated 1,2 times in accordance with the heat (this is a detailed heating load calculation to realise thanks to the indication of the boiler size performance as listed below).

Output practice at different fuel grades:

SYNCHRO 34

Biggest output during the practice with soft wood	34 kW
Biggest output with hard wood	36 kW

SYNCHRO 44

Biggest output during the practice with soft wood	42 kW
Biggest output with hard wood	44 kW

Max. 250 m ² living space	little insulated	heat power: approx. 30 kW	Synchro 34
Max. 400 m ² living space	very well insulated	heat power: approx. 30 kW	Synchro 34
Max. 350 m ² living space	little insulated	heat power: approx. 40 kW	Synchro 44
Max. 500 m ² living space	very well insulated	heat power: approx. 38 kW	Synchro 44

3.4 Boiler room

Please see the valid boiler room specifications for the relevant requirements. The boiler room must be frost-proof. When the system is in operation, the boiler room temperature must lie between 10 – 40°C.

Legend

- A Installation site entrance
- B SYNCHRO
- C Combustion air supply
- D Outlet for safety valve
- E Electrical connection
- F Flue diameter
- G Admixed air installation as draw limit, cleaning aperture and pressure relieving flap
- H Space at the back at least 40 cm

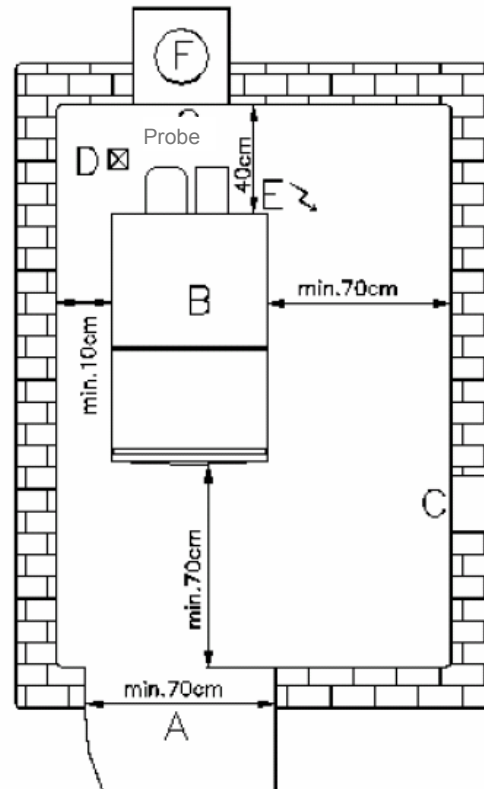

Installation to site

The **SYNCHRO** is delivered with full wiring and insulation. Including insulation, the boiler has a width of 1056 mm, a depth of 914 mm and a height of 1300 mm.

Boiler dimensions without insulation: width: 695 mm; depth: 1140 mm; height: 1290 mm. The entrance to the installation site should therefore be a minimum of 700 mm wide.

Installation site

Place the system close to the flue, in order to avoid a lengthy exhaust gas pipe. Please observe the following points:

- The distance from the wall on the left side (right) must be min. **10 cm**.
- The distance from the wall on the right side (left) must be min. **70 cm**.
- The distance to the rear wall must be min. **40 cm**.
- The space in front of the boiler must be of **70 cm**. The filling chamber doors must be kept free

Combustion air supply

The combustion air supply must be fed in from outside and constantly guaranteed. Please observe the following points:

- The vacuum in the boiler room must not lie above 3 Pa (0.3 mmWS).
- It is necessary to provide a non-closing opening of minimum **300 cm²** for ventilation and aeration (where necessary a pipe with a min. diameter of 20 cm must be fed through the external wall).
- If a lattice grate is to be installed to the hole, then the opening should be larger to reflect the dimensions of the grate, the mesh size must be minimum 1 cm².
- The combustion air supply should, if possible, be close to the ground, in order to prevent the boiler room from cooling down.

3.5 Flue and flue connection

- Use moisture insensitive, heat insulated fireclay flues (Guntamatic takes no responsibility for stainless steel flues!!!); brick flues, if they are in order and meet the required standards, will not need to be cleaned up. Ask the relevant sweeps!

Flue cross-section guide value:

- Synchro 34 effective height < 5 m diameter 200 mm
- Synchro 34 effective height > 5 m diameter 180 mm
- Synchro 44 effective height > 5 m diameter 180 mm

Flue calculations

Boiler type	Exhaust gas temp in °C		CO2 in %		Exhaust gas mass flow Kg/s		Draw required mbar
	Nominal load	Partial load	Nominal load	Partial load	Nominal load	Partial load	
Synchro 31	175-155	155-150	12-13	11-12	0,02	0,010	0,20
Synchro 34	175-155	155-150	12-13	11-12	0,02	0,010	0,20
Synchro 44	185-165	165-160	13-14	11-12	0,028	0,011	0,20

Smoke pipe connection

- The smoke pipe Synchro 34/44 must increase at a min. diameter of 150 mm without unnecessary bends as possible in order to connect it directly to the boiler!
- Exhaust gas pipes longer than 4 m or with more than 3 bends diam. 180 mm should be applied.
- The smoke pipe must not display any rigid connection with the boiler – sound transmission!! (Sealing gasket or sealing cord inlay!!)
- The smoke pipe must be insulated!!

Flue draw regulator

The installation of a flue draw regulator is essential. This carries out the following functions:

- Ventilates the flue whilst the system is non-operational.
- Compensates for excess pressure during a pressure surge.
- Regulates and limits the output pressure (flue draw).
- A flue draw regulator (diam. 200 mm as possible) should be installed ideally in the boiler below the smoke gas tube, alternatively the energy-saving draw regulator can also be installed in the smoke pipe as near to the flue as possible.
- The requisite flue draw (20Pa, 0,2mbar) must imperatively be measured and set.

Flue caps and cowls

These must be manufactured in non-combustible materials and must not restrict the flue cross-section, reduce the output pressure (flue draw) or restrict cleaning the flue. The exhaust gases should be able to exit the flue outlet vertically without impedance. The fastening mechanism must be able to resist strong buffeting.

3.6 Hydraulic connections

The operation of the **SYNCHRO** will require the provision of the following system components on site:

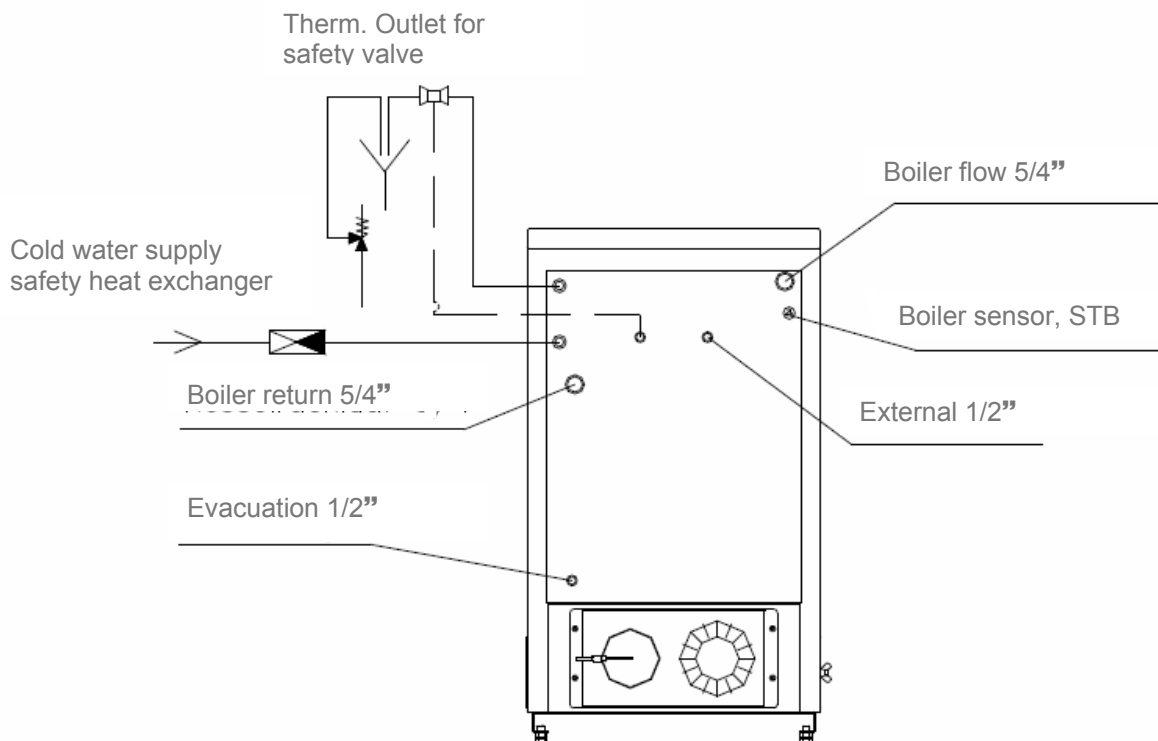

Expansion chamber

The **SYNCHRO** is operated in a closed system and must have an expansion chamber. In order to calculate the expansion volume it is necessary to know the volume of the cold system (boiler, buffer, lines and radiators).

The expansion volume of the system is calculated using:

System volume x expansion factor x loading factor

Return flow bypass

- We recommend that you use our return flow bypass group RA 60 art. No.: H 39-001. (Return flow bypass by means of a thermostatic valve that has a return flow of over 55°C when open and of 70°C when completely open.)
- A return temperature of 50°C is mandatory required!!
- A return temperature regulator in the bypass is non-permissible (because not fail-safe)!

Security device

- An opening temperature of 95°C on site should be expected to connect the flue, according to the thermal safety outlet ÖNORM B 8131.

3.7 Electrical connection

The **SYNCHRO** is connected via plug and socket connections at the front of the boiler.

Plan for the following connection and supply lines:

Main supply

The **SYNCHRO** is supplied with 230 V, 50 Hz, 13 A from the main *network* via the plug and socket connection on the rear wall of the boiler.

Pre-wiring

If an external temperature regulator or additional devices are to be attached, then the following wiring should be provided:

External sensor: 2 x 1 mm²
Room sensor RFF25: 2 x 0,75 mm²
Room station RS100: 3 x 2 x 0,25 paired, sheathed (2 wires reserve)

3.8 Heat distribution

Pump control

Boiler supercharger and storage supercharger are speed regulated. Time programme for storage charge pump and heating pumps in the basic version.

Attachments

Hydraulic diagram: SYNCHRO without weather controlled regulator	14
Hydraulic diagram: SYNCHRO with weather controlled regulator	15
Hydraulic diagram: SYNCHRO with oil or gas boiler	16
Hydraulic diagram: SYNCHRO with oil or thermal gas	17
Information about the integrated interlocking burner	18
Hydraulic diagram: SYNCHRO with oil or gas boiler (MK-regulator in the oil boiler)	19
Technical data	20

Hydraulic diagram: SYNCHRO with buffer storage and hot water storage

GUNTAMATIC

TEL: 07276 2441-0 FAX: 3031
 homepage: www.guntamatic.com

GUNTAMATIC COMPONENTS

1. SYNCHRO 34 / 44
2. Draw regulator RK (size depending on flue diameter)
3. Return flow bypass group RA60 (5/4", with pump 32-60)
4. AKKUTHERM PS (min. 40 litres / KW boiler output)
5. Industrial water – extra boiler SB (200, 300 or 500 litres)

Attached diagram SYNCHRO – Buffer storage (AKKUTHERM PS) hot water storage (SB) without weather controlled regulator

Synchro diagram 1
 (Electrical plan in accordance with the instruction and installation manual)

ATTENTION:
 No starter connection between boiler and smoke pipe (fibreboard, sealing cord....)

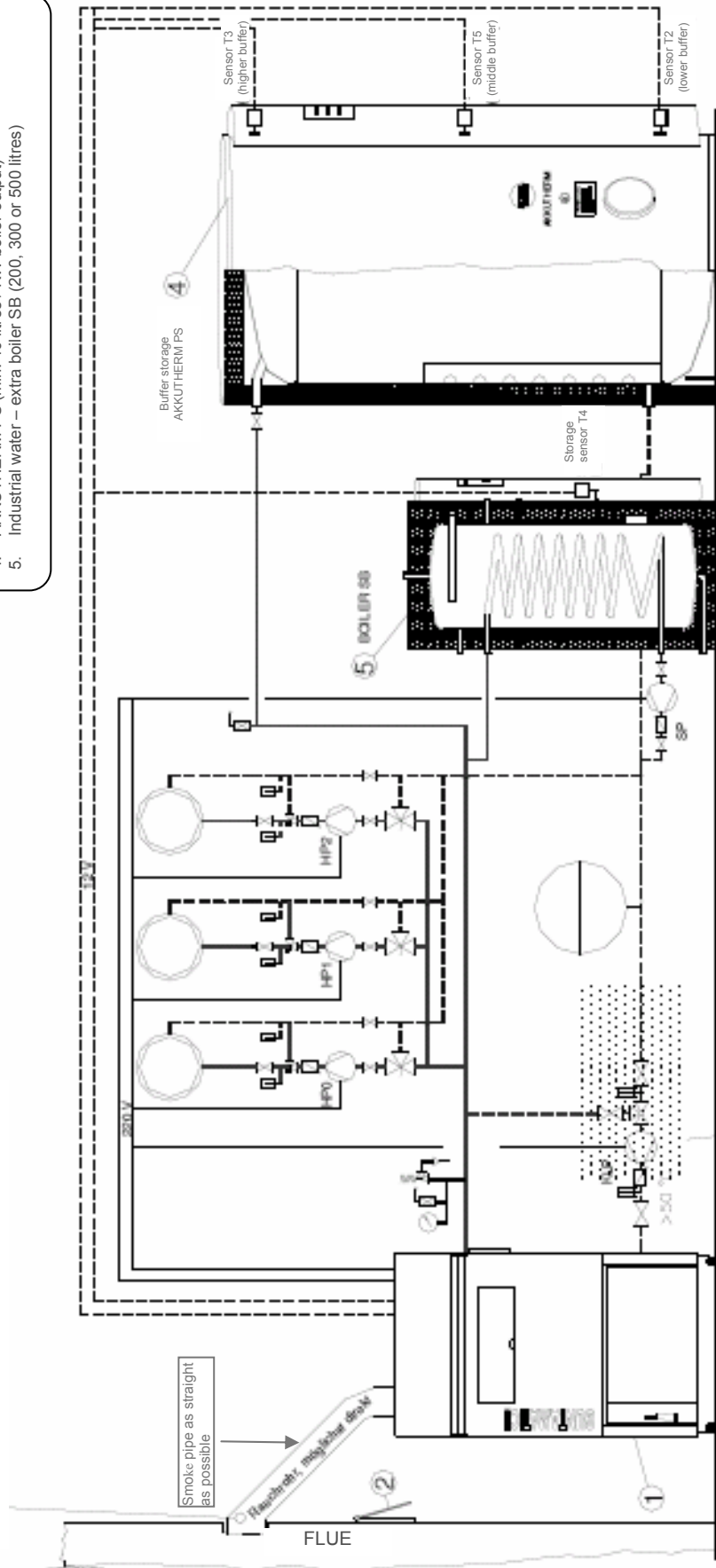

Heat of the future

Hydraulic diagram: SYNCHRO with buffer storage and hot water storage with weather controlled regulator

GUNTAMATIC
 TEL: 07276 24410 FAX: 3035
 http://www.guntamatic.com

GUNTAMATIC COMPONENTS

1. SYNCHRO 34 / 44
2. Draw regulator RK (size depending on flue diameter)
3. Return flow bypass group RA60 (5/4", with pump 32-60)
4. AKKUTHERM PS (min. 40 litres /KW boiler output)
5. Industrial water – extra boiler SB (200, 300 or 500 litres)
6. Weather controlled regulator: MK 231 (for 1 mixed circuit)
 MK 261 (for 2 mixed circuits)
7. Servomotor SM70 (for all conventional mixing valves)
8. If desired: max. 1 room sensor RFF 25 per mixed circuit
9. If desired: max. 1 room station RS 100 per mixed circuit

Attached diagram SYNCHRO – Buffer storage (AKKUTHERM PS) hot water storage (SB) with weather controlled regulator

Synchro diagram 2
 (Electrical connexion in accordance with the instruction and installation manual)

ATTENTION:
 No starter connection between boiler and smoke pipe (fibreboard, sealing cord....)

Attention:
 In addition to the mixed circuit, HKPO output may be used as time control. (A mixer control is not possible with this output. If necessary, a thermostat set-up for the pump can be installed thanks to a room unit RFF 25.)

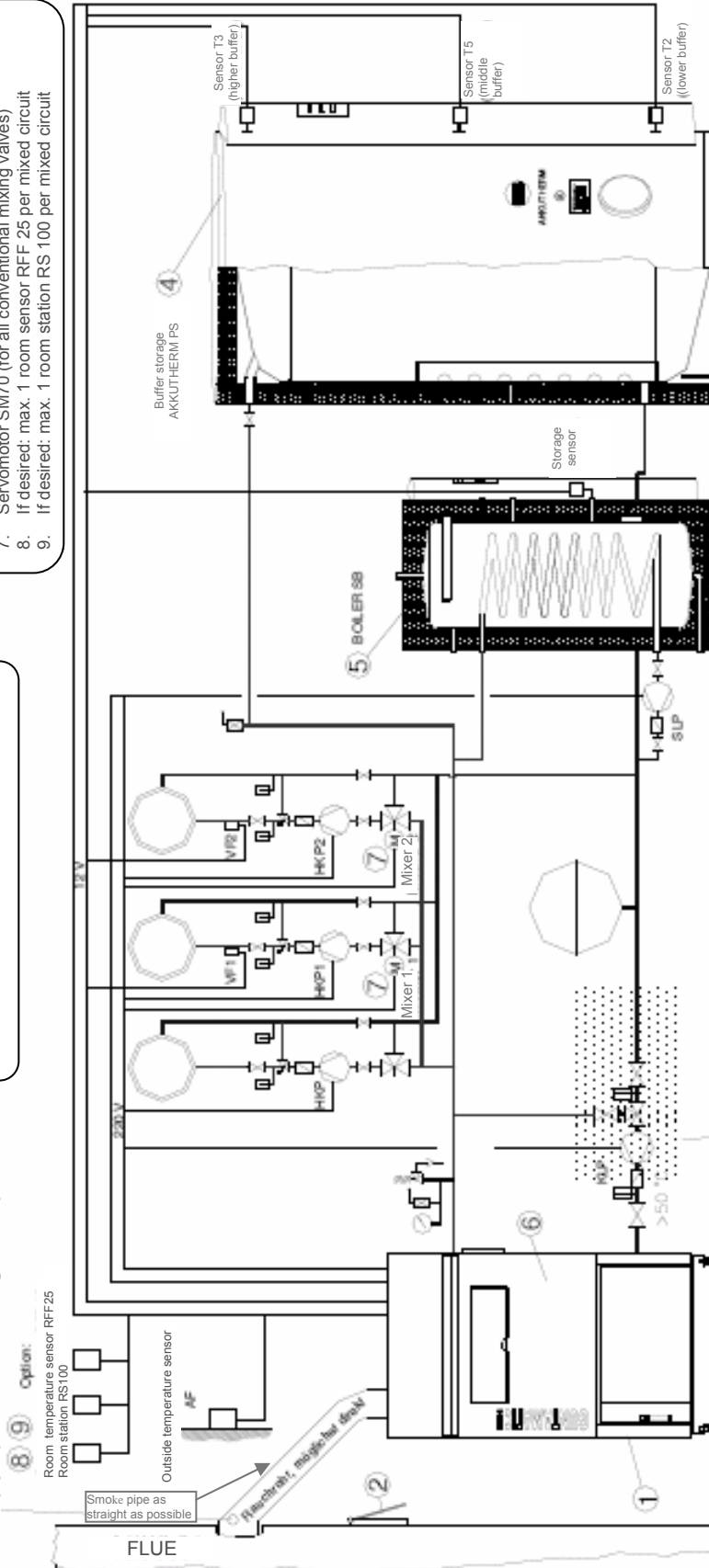

Heat of the future

Hydraulic diagram: SYNCHRO with oil or gas boiler



GUNTAMATIC COMPONENTS

1. Wood carburettor Synchro
2. Draw regulator RK (size depending on flue diameter)
3. Return flow bypass group RA60 (5/4" , with pump 32-60) H39-001
4. AKKUTHERM PS (min. 40 litres /KW boiler output)
5. Industrial water – extra boiler SB (200, 300 or 500 litres)
6. Weather controlled regulator: MK 231 (for 1 mixed circuit) S30-021 MK 261 (for 2 mixed circuits) S30-022
7. Servomotor SM70
8. If desired: max. 1 room sensor RFF 25 S70-006 1 room station RS100 S60-003
9. Oil or gas boiler
10. Mixer (1" - 3/4" Weg AUF/ZU)
11. Boiler sensor T4 oil art. no. S70-004

Attached diagram SYNCHRO, oil or gas boiler – buffer storage AKKUTHERM, boiler, outside temperature controller MK231 / (261) in the Synchro

Diagram no. SYNCHRO 16

Electrical plan in accordance with the instruction and installation manual Attention : not suitable for thermal gas

Function : if higher buffer (T3) < required temperature and the RGT < 130°C (RGT-burner) then the oil burner will be controlled over the HPO output (interlock). During this phase the mixer will be controlled simultaneously. Consequently, the burner will start working with the mixer on position A-C. Simultaneously the boiler temperature in the gas boiler (T4) will be used as a start-up temperature if it exceeds 45°C (T4 – burner).

If T3 > requirement or T4 > requirement + 6°C (diff. burner) or RGT (BMK) > 130°C (RGT – burner), the HPO output (interlock) will be out of service again. If the boiler temperature in the oil boiler (T4) falls below 45°C (T4 – burner) – 3°C, the output HP2 will be controlled during 3 minutes (LZ – interlock). Simultaneously the probe value T3 (buffer higher) will be reused as a start-up temperature.

Output – burner = A – C passage (buffer interlock)
Output HP2 = A – B passage

OPTION :
Room temperature sensor RFF25
Room station RS100

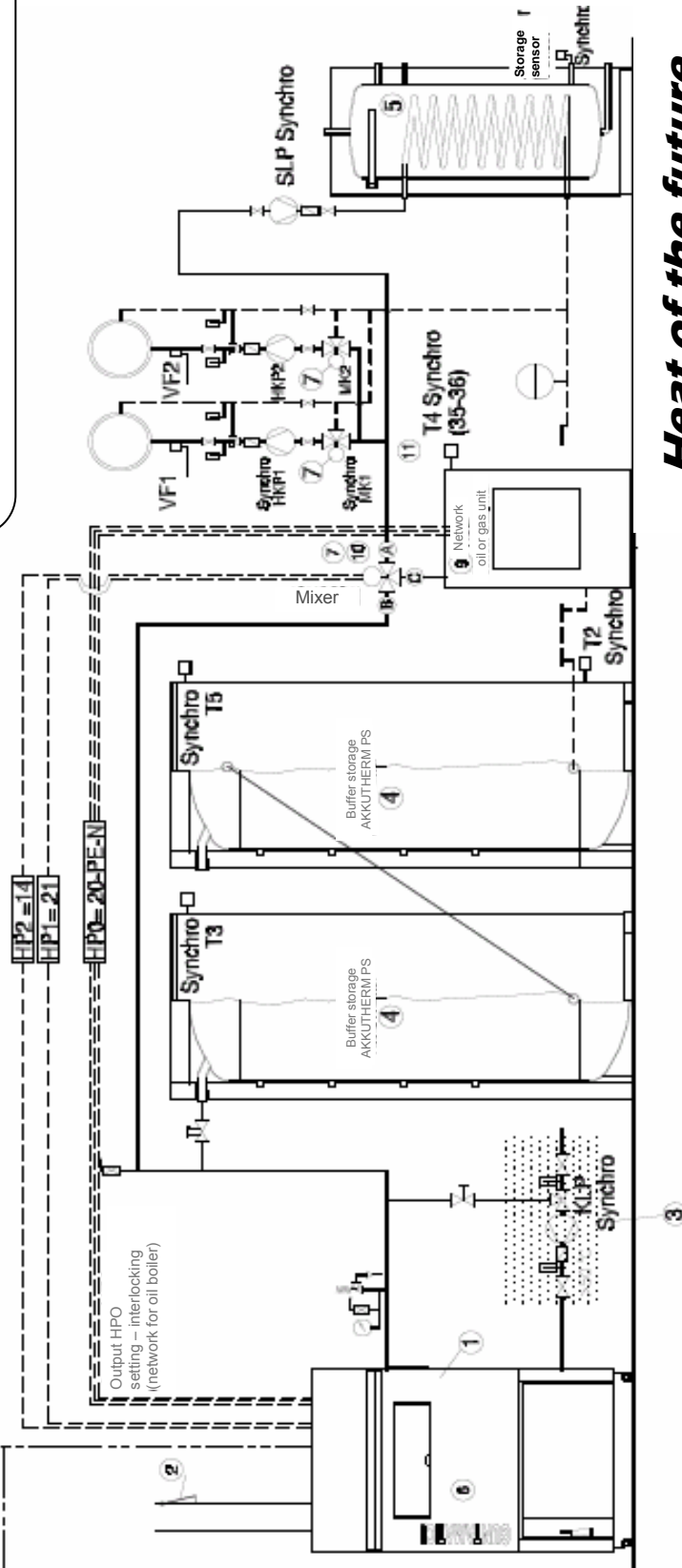
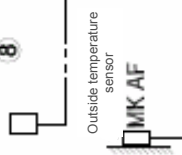

Heat of the future

Hydraulic diagram: SYNCHRO with oil or thermal gas



GUNTAMATIC COMPONENTS

1. Wood carburettor Synchro
2. Draw regulator RK (size depending on flue diameter)
3. Return flow bypass group RA60 (5/4", with pump 32-60) H39-001
4. AKKUTHERM PS (min. 40 litres / KW boiler output)
5. Industrial water – extra boiler SB (200, 300 or 500 litres)
6. Weather controlled regulator: MK 231 (for 1 mixed circuit) S30-021 MK 261 (for 2 mixed circuits) S30-022
7. Servomotor SM70
8. If desired: max. 1 room sensor RFF25 S70-006 1 room station RS100 S60-003
9. Oil or thermal gas
10. Mixer (1" - 3Weg AUFZU)
11. Boiler sensor T4 oil art. no. S70-004

Attached diagram SYNCHRO, oil or gas boiler – buffer storage AKKUTHERM, boiler, outside temperature controller MK231 / (261) in the Synchro

Diagram no. SYNCHRO-16-sonde (also suitable for thermal gas)

Function : if higher buffer (T3) < required temperature and the RGT < 130°C (RGT-burner) then the oil burner will be controlled over the HPO output (interlock). During this phase the mixer will be controlled simultaneously. Consequently, the burner will start working with the mixer on position A-C. Simultaneously the boiler temperature in the gas boiler (T4) will be used as a start-up temperature if it exceeds 45°C (T4 – burner).

If T3 > requirement or T4 > requirement + 6°C (diff. burner) or RGT (BMK) > 130°C (RGT – burner), the HPO output (interlock) will be out of service again. If the boiler temperature in the oil boiler (T4) falls below 45°C (T4 – burner) – 3°C, the output HP2 will be controlled during 3 minutes (LZ – interlock). Simultaneously the probe value T3 (buffer above) will be reused as a start-up temperature.

Output – burner = A – C passage (buffer interlock)
Output HP2 = A – B passage

Attention : In the parameter menu HPO the "DELAY" must be set on 4 minutes

OPTION :
Room temperature sensor RFF25
Room station RS100

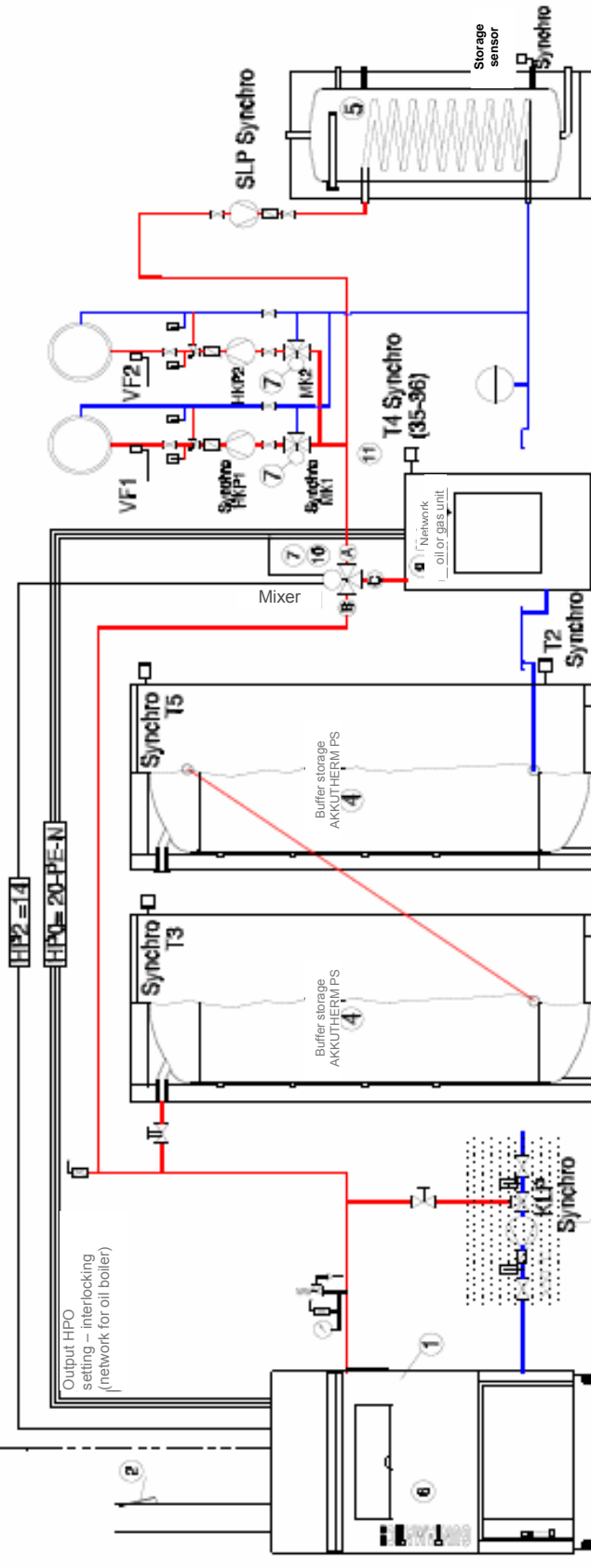
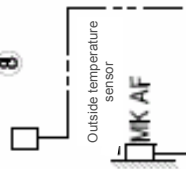

Heat of the future

The integrated interlocking burner is available from software **BMK-SYNCHRO 2.0**.

If the new Eprom is set in subsequently, a reset control must be performed.

The system has to be re-configured (startup menu).

The Eprom 2.0 is only suitable for the hardware 2.0.

(System from July 2006; sticker on the rear display "suitable for Eprom 2.0")

1) Interlocking burner integrates:

(only applicable if the weather controlled regulator is installed in the BMK or Synchro)

1.1) Installation according to circuit diagram: BMK-Synchro 16 and BMK-Synchro 16-probe (for thermal gas)

1.2) As the HP2 output is a Triac output, the mixer engine would be suitable for the control by a Triac output.

(For ex. Kromschöder SM70, Kromschöder SM40C, Belimo LR230 A, Wita SM40C)

If the mixer engines are not suitable for a Triac output, then the HP2 output (terminal 14) must be led on a standard relay.

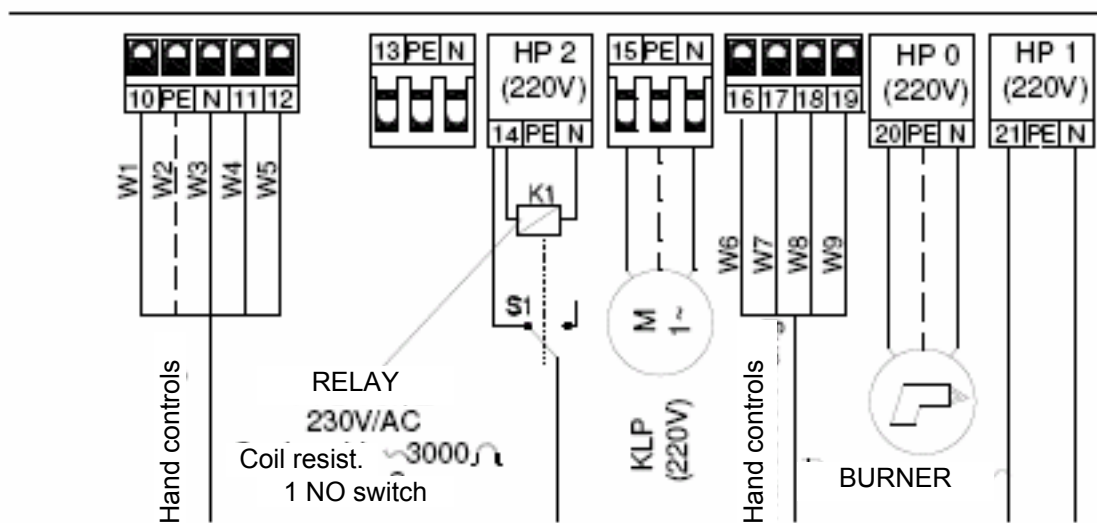

Attention:

The relay is only needed in the mixer control;
not necessary when the HP2 output is used as a heating pump output!

1.3) Installation according to diagram Synchro 16:

As the selector valve is an essential 3-way mixer
Operation HPO = interlock

1.4) Installation according to diagram Synchro 16-probe (for thermal gas):

As the selector valve is an essential 3-way mixer
Operation HPO = interlock

In the HPO parameter menu, the "delay" parameter must be set on 4 minutes.

Technical data

		TYPE	SYNCHRO 31/34	SYNCHRO 44
Heating performance		KW	31 /34	44
		Mcal / h	26,6 / 29	38
Boiler:	Width measurement D	mm	745	745
	Height measurement E	mm	1300	1300
	Depth measurement F	mm	1195	1195
Fuel volume		litres	170	170
Filling chamber width		mm	535	535
Depth of combustion chamber		mm	340	340
Water content		litres	125	125
Operating pressure max.		bar	3	3
Transportation weight approx		Kg	650	660
Supply and return flow		inch	RI 1/4	RI 1/4
Measurement A		mm	1165	1165
Measurement B		mm	905	905
Smoke pipe connection measurement C (without knee)		mm	215	215
Smoke pipe diameter		mm	150	150
Induced draught ventilator		kWh	0,12	0,12
Draught necessary		PA	20	20
Boiler size without insulation	Width	mm	695	695
	Height	mm	1290	1290
	Depth	mm	1140	1140
Flange (alternative)	Inner diameter G		110	110
	Height H		880	880

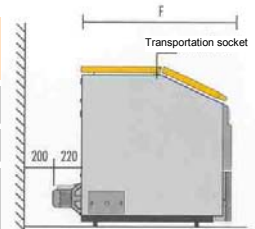

Safety battery Sensor for Safety battery

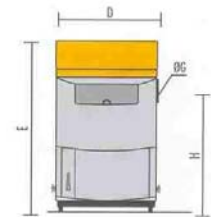
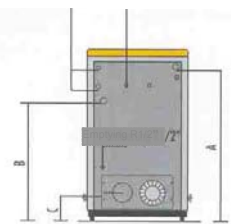

GUNTAMATIC Heiztechnik GmbH
 A-4722 Peuerbach, Bruck-Waasen 7
 Tel. 0043 (0) 7276/2441-0, Fax 0043 (0) 7276/3031
 e-mail: info@guntamatic.com
 homepage: www.guntamatic.com